

仅供参考

REV.	REVISION RECORD	DATE
A0	新图面发行	2017.06.16

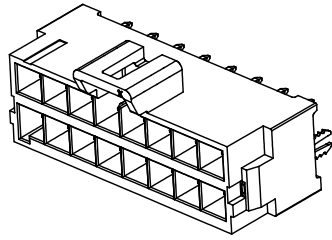

Specifications:
 Voltage Rating : 250V AC/DC
 Current Rating : 7A AC,DC
 Withstand Voltage : 1500V AC/minute
 Contact Resistance : 40mΩ(MAX.)
 Insulation Resistance : 1000MΩ(MIN.)
 Temperature Range : -40°C~+120°C

STP43501W00-2XNP*-B2-**

STP43501W01-2XNP*-B2-**

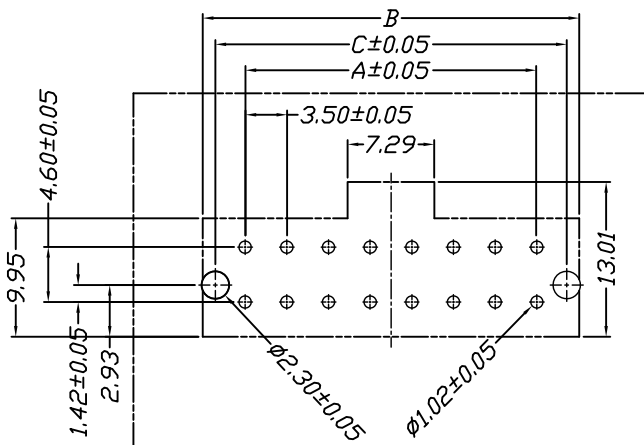
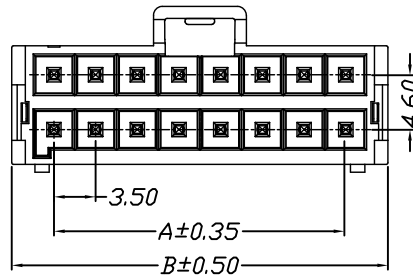
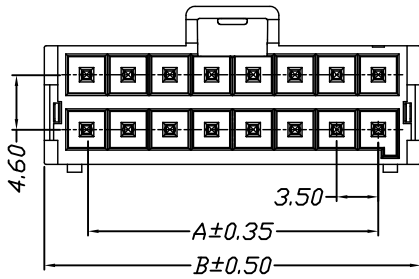
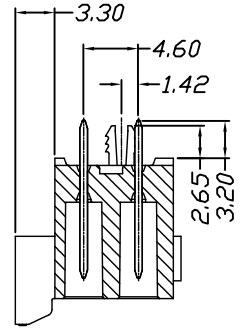
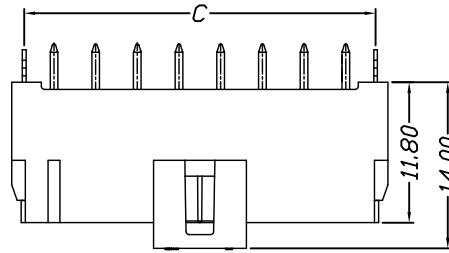
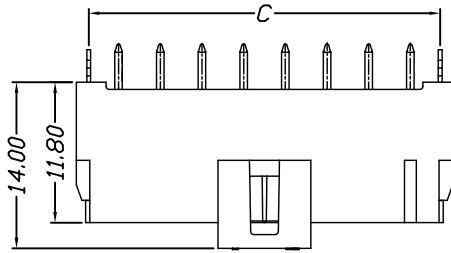

P.C.B. LAYOUT

Poles	Dimensions		
	A	B	C
2*2P	3.50	10.60	8.50
2*3P	7.00	14.10	12.00
2*4P	10.50	17.60	15.50
2*5P	14.00	21.10	19.00
2*6P	17.50	24.60	22.50
2*7P	21.00	28.10	26.00
2*8P	24.50	31.60	29.50

Material	Color	PIN Material
LCP	Black	Brass/Tin-plated

GENERAL TOLERANCES	LINEAR	ANGLES	SCALE:	NAME	DATE
	0.0±0.35	X° REF±6°	1:1		
UNIT: MM	0.00±0.25	X° ±3°	APPROVED		
SIZE: A4	0.000±0.15	X° X'±2°	DESIGNER		
			DRAWN	肖坤权	2017.06.16

STP 深圳市思拓展电子有限公司
 SHENZHEN SINOTOP ELECTRONICS CO., LTD
 公司网址: www.szsituo.cn 公司电话: 0755-23765350
 电子邮箱: 2850175982@qq.com 公司传真: 0755-23765341

TITLE:
 3.50mm Pitch 180° Dual Wafer DIP Type

PART NO:	STP43501W0X-2XNPX-B2-XX	
DWG. NO:		
REV:	A0	SHEET: 1/1

仅供参考

REV.	REVISION RECORD	DATE
A0	新图面发行	2017.06.16

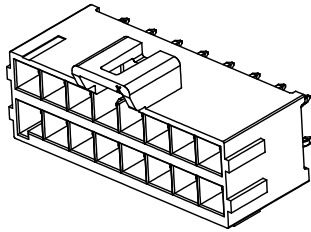

Specifications:
 Voltage Rating : 250V AC/DC
 Current Rating : 7A AC,DC
 Withstand Voltage : 1500V AC/minute
 Contact Resistance : 40mΩ(MAX.)
 Insulation Resistance : 1000MΩ(MIN.)
 Temperature Range : -40°C~+120°C

STP43501W00-2XNP*-B3-**

STP43501W01-2XNP*-B3-**

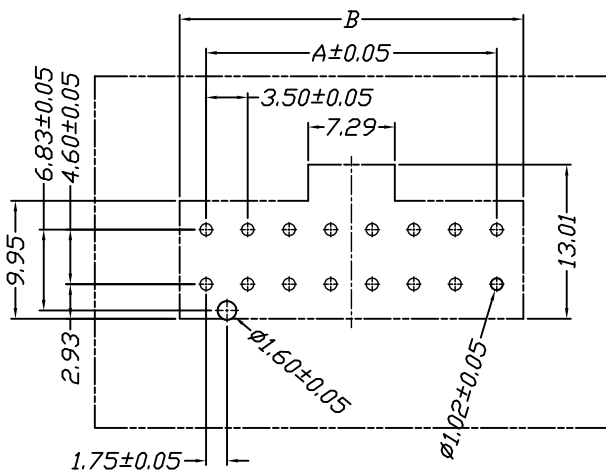
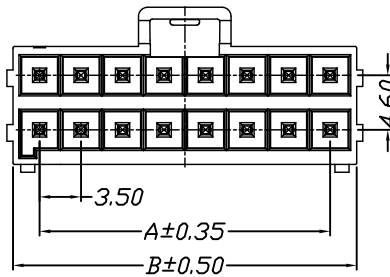
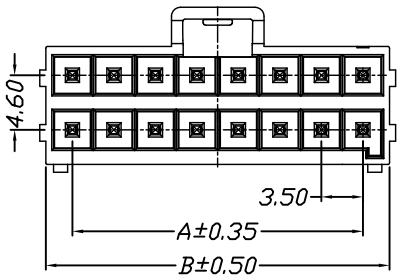
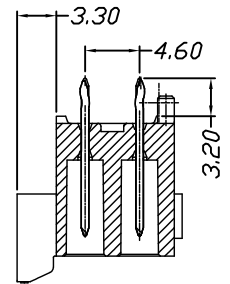
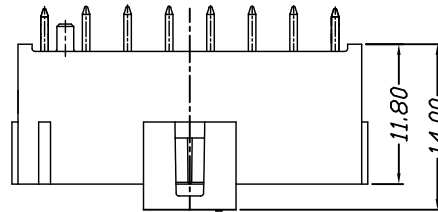
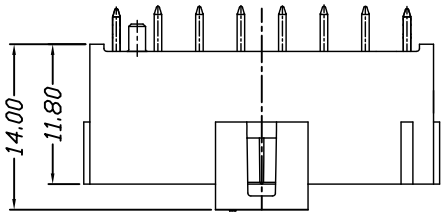

P.C.B. LAYOUT

Poles	Dimensions	
	A	B
2*2P	3.50	8.00
2*3P	7.00	11.50
2*4P	10.50	15.00
2*5P	14.00	18.50
2*6P	17.50	22.00
2*7P	21.00	25.50
2*8P	24.50	29.00

Material	Color	PIN Material
LCP	Black	Brass/Tin-plated

	GENERAL TOLERANCES		SCALE: 1:1	NAME	DATE
	LINEAR	ANGLES			
0.0±0.35	X° REF±6°	APPROVED			
UNIT: MM	0.00±0.25	X° ±3°	DESIGNER		
SIZE: A4	0.000±0.15	X° X'±2°	DRAWN	肖坤权	2017.06.16

深圳市思拓展电子有限公司
 SHENZHEN SINOTOP ELECTRONICS CO., LTD
 公司网址: www.szsituo.cn 公司电话: 0755-23765350
 电子邮箱: 2850175982@qq.com 公司传真: 0755-23765341

TITLE:
3.50mm Pitch 180° Dual Wafer DIP Type

PART NO:	STP43501W0X-2XNPX-B3-XX	
DWG NO:		
REV:	A0	SHEET: 1/1

A B C D E F G H

仅供参考

REV.	REVISION RECORD	DATE
A0	新图面发行	2017.06.16

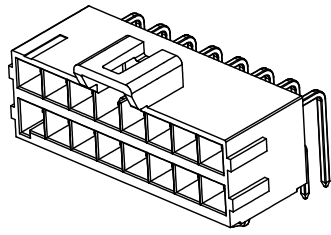

Specifications:
 Voltage Rating : 250V AC/DC
 Current Rating : 7A AC,DC
 Withstand Voltage : 1500V AC/minute
 Contact Resistance : 40mΩ(MAX.)
 Insulation Resistance : 1000MΩ(MIN.)
 Temperature Range : -40°C~+120°C

STP43501W90-2XNP*-B3-**

STP43501W91-2XNP*-B3-**

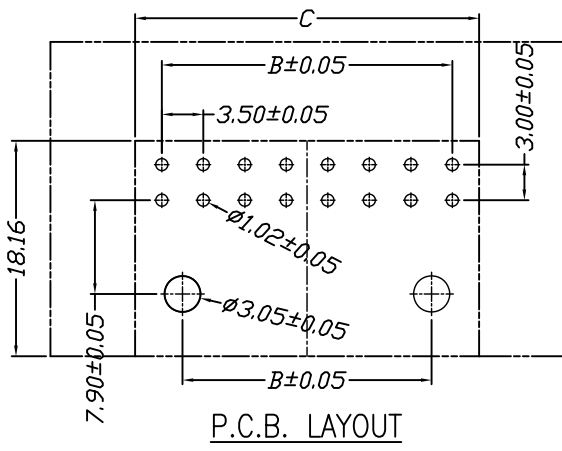
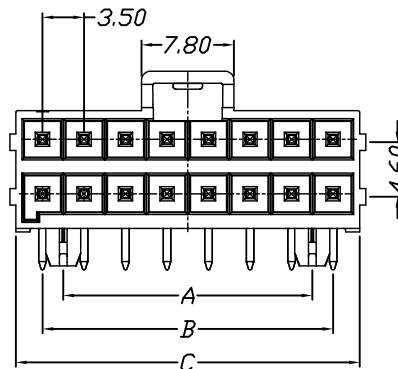
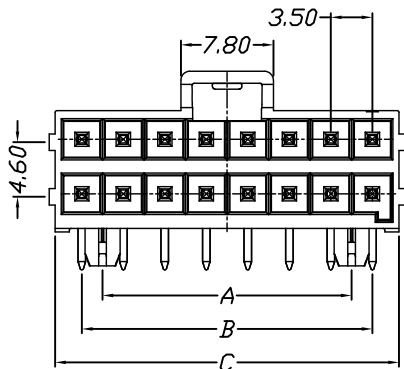
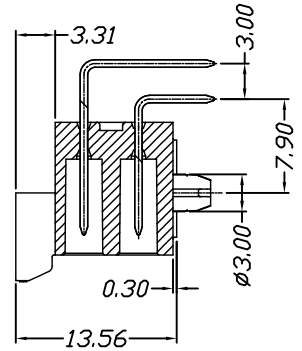
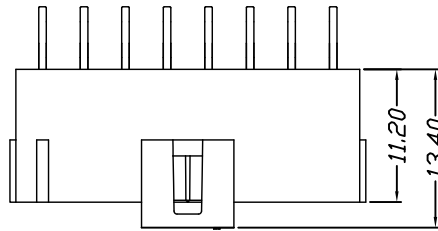
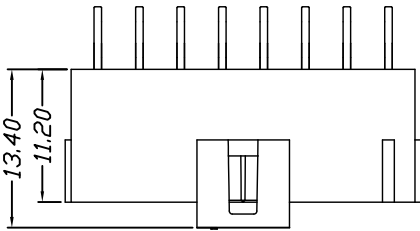

Poles	Dimensions		
	A	B	C
2*2P	—	3.50	8.00
2*3P	—	7.00	11.50
2*4P	7.00	10.50	15.00
2*5P	10.50	14.00	18.50
2*6P	14.00	17.50	22.00
2*7P	17.50	21.00	25.50
2*8P	21.00	24.50	29.00

Material	Color	PIN Material
LCP	Black	Brass/Tin-plated

	GENERAL TOLERANCES		SCALE: 1:1	NAME	DATE
	LINEAR	ANGLES			
UNIT: MM	0.00±0.25	X° ±3°	APPROVED		
SIZE: A4	0.000±0.15	X° X'±2°	DESIGNER		
			DRAWN	肖坤权	2017.06.16

深圳市思拓展电子有限公司
 SHENZHEN SINOTOP ELECTRONICS CO., LTD
 公司网址: www.szsituo.cn 公司电话: 0755-23765350
 邮箱: 2850175982@qq.com 公司传真: 0755-23765341

PART NO:	STP43501W9X-2XNPX-B3-XX	
DWG NO:		
REV:	A0	SHEET: 1/1

TITLE:
3.50mm Pitch 90° Dual Wafer DIP Type

仅供参考

REV.	REVISION RECORD	DATE
A0	新图面发行	2017.06.16

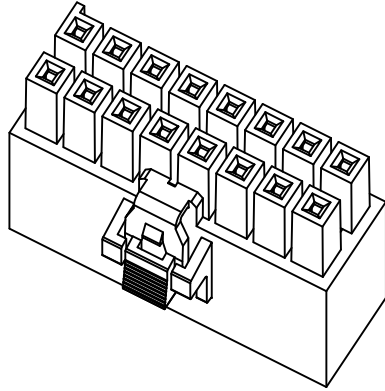

Specifications:
 Voltage Rating : 250V AC/DC
 Current Rating : 7A AC,DC
 Withstand Voltage : 1500V AC/minute
 Contact Resistance : 40mΩ(MAX.)
 Insulation Resistance : 1000MΩ(MIN.)
 Temperature Range : -40°C~+120°C

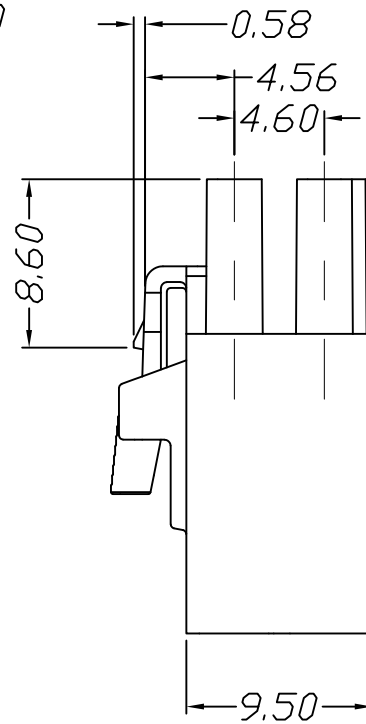
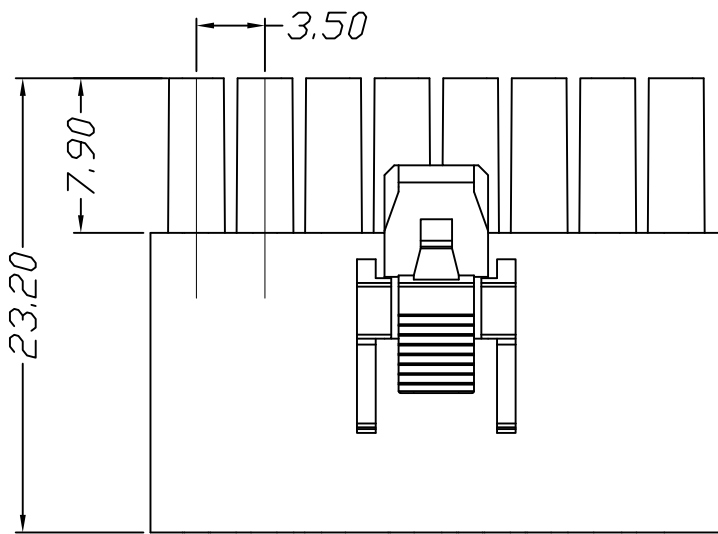
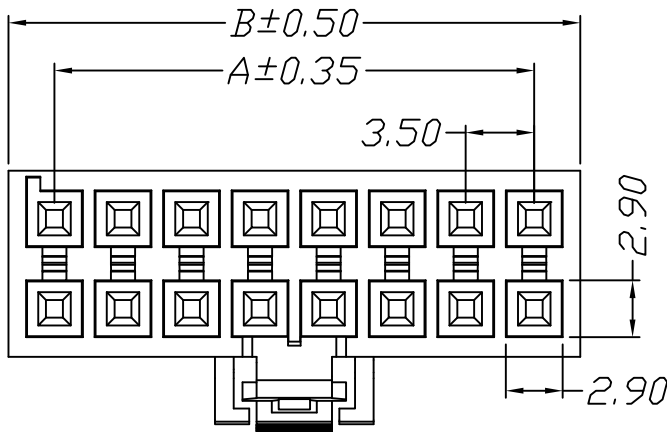

Poles	Dimensions	
	A	B
2*2P	3.50	8.20
2*3P	7.00	11.70
2*4P	10.50	15.20
2*5P	14.00	18.70
2*6P	17.50	22.20
2*7P	21.00	25.70
2*8P	24.50	29.20

Material	Color
PA6T UL94V-0	BLACK

	GENERAL TOLERANCES		SCALE: 1:1	NAME	DATE	深圳市思拓展电子有限公司 SHENZHEN SINOTOP ELECTRONICS CO., LTD 公司网址: www.szstuo.cn 公司电话: 0755-23765350 邮箱: 2850175982@qq.com 公司传真: 0755-23765341	PART. NO: STP43501H00-2XNPX-6T
	LINEAR	ANGLES					
UNIT: MM	0.00±0.25	X° ±3°	DESIGNER			TITLE:	DWG. NO:
SIZE: A4	0.000±0.15	X° X' ±2°	DRAWN	肖坤权	2017.06.16	3.50mm PITCH Housing	REV: A0 SHEET: 1/1

仅供参考

REV.	REVISION RECORD	DATE
A0	新图面发行	2017.06.16

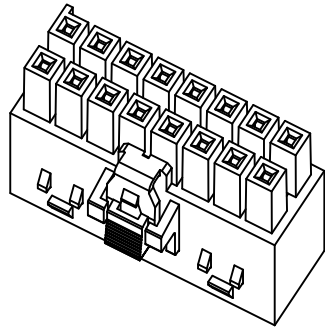

Specifications:
 Voltage Rating : 250V AC/DC
 Current Rating : 7A AC,DC
 Withstand Voltage : 1500V AC/minute
 Contact Resistance : 40mΩ(MAX.)
 Insulation Resistance : 1000MΩ(MIN.)
 Temperature Range : -40°C~+120°C

STP43501H00-2XNP*-G1-**

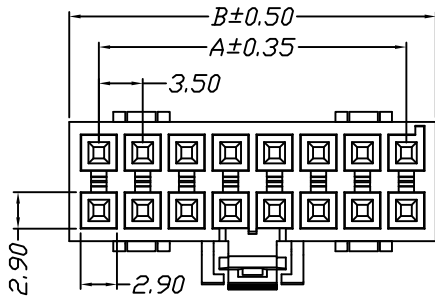

STP43501H01-2XNP*-G1-**

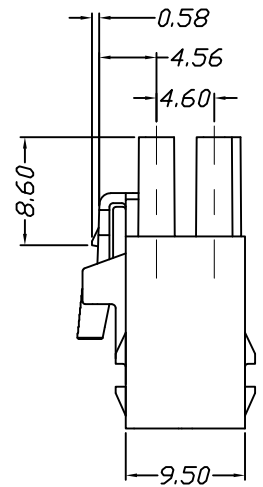
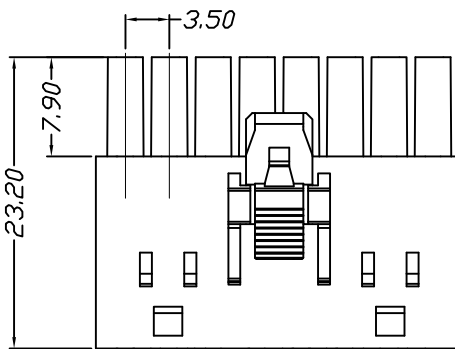
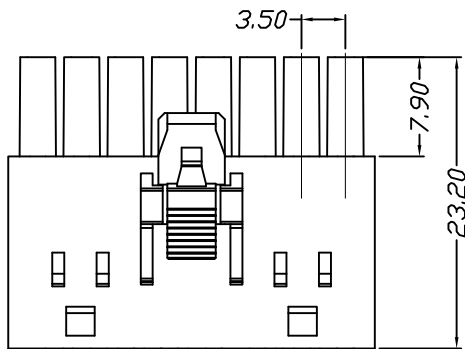
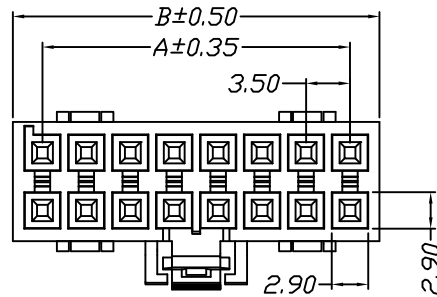

Poles	Dimensions	
	A	B
2*2P	3.50	8.20
2*3P	7.00	11.70
2*4P	10.50	15.20
2*5P	14.00	18.70
2*6P	17.50	22.20
2*7P	21.00	25.70
2*8P	24.50	29.20

Material	Color
PA6T UL94V-0	BLACK

	GENERAL TOLERANCES		SCALE: 1:1	NAME	DATE	深圳市思拓展电子有限公司 SHENZHEN SINOTOP ELECTRONICS CO., LTD 公司网址: www.szstuo.cn 公司电话: 0755-23765350 电子邮箱: 2850175982@qq.com 公司传真: 0755-23765341	PART. NO: STP43501H0X-2XNPX-G1-XX
	LINEAR	ANGLES					
	0.0±0.35	X° REF±6°	DESIGNER				
UNIT: MM	0.00±0.25	X° ±3°	DESIGNER	TITLE:	3.50mm PITCH Housing	DWG. NO:	REV: A0
SIZE: A4	0.000±0.15	X° X'±2°	DRAWN	肖坤权	2017.06.16	SHEET: 1/1	

仅供参考

REV.	REVISION RECORD	DATE
A0	新图面发行	2017.06.16

Specifications:
 Voltage Rating : 250V AC/DC
 Current Rating : 7A AC,DC
 Withstand Voltage : 1500V AC/minute
 Contact Resistance : 40mΩ(MAX.)
 Insulation Resistance : 1000MΩ(MIN.)
 Temperature Range : -40°C~+120°C

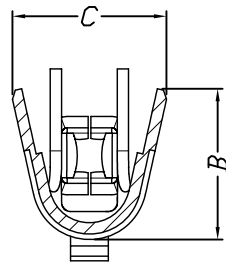
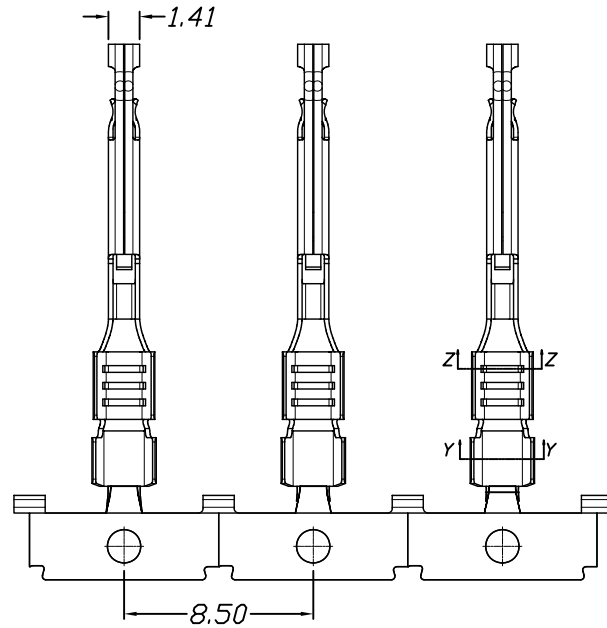
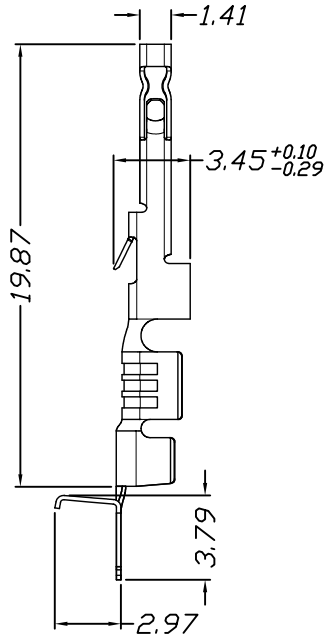

SECTION Z-Z

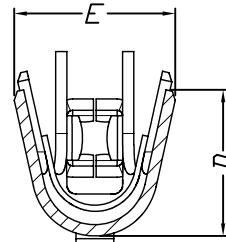

SECTION Y-Y

Part No.	Dimensions			
	B	C	D	E
43501TOP-**	2.71	2.77	2.63	2.89
423501T1P-**	2.16	2.20	2.08	2.33

Part No	Wire Range	Insulation O. D.	Material	Finish	Qty/Reel
43501TOP-**	AWG #16~#18	1.70mm Max	Phosphor bronze	Au or Sn	
423501T1P-**	AWG #20~#22	1.30mm Max			

	GENERAL TOLERANCES		SCALE: 1:1	NAME	DATE	深圳市思拓展电子有限公司 SHENZHEN SINOTOP ELECTRONICS CO., LTD 公司网址: www.szsituo.cn 公司电话: 0755-23765350 邮箱: 2850175982@qq.com 公司传真: 0755-23765341	PART. NO: STP43501XP-XX	
	LINEAR	ANGLES	APPROVED				DWG. NO:	
	0.0±0.35	X° REF±6°	DESIGNER				REV: A0 SHEET: 1/1	
	UNIT: MM	0.00±0.25	X° ±3°	DRAWN	肖坤权		2017.06.16	TITLE: 3.50mm PITCH Crimp Terminal
SIZE: A4	0.000±0.15	X° X'±2°						

仅供参考

REV.	REVISION RECORD	DATE
A0	新图面发行	2017.06.16

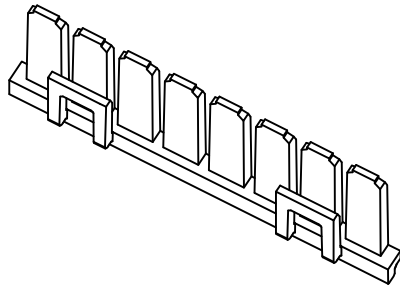

Specifications:
 Voltage Rating : 250V AC/DC
 Current Rating : 7A AC,DC
 Withstand Voltage : 1500V AC/minute
 Contact Resistance : 40mΩ(MAX.)
 Insulation Resistance : 1000MΩ(MIN.)
 Temperature Range : -40°C~+120°C

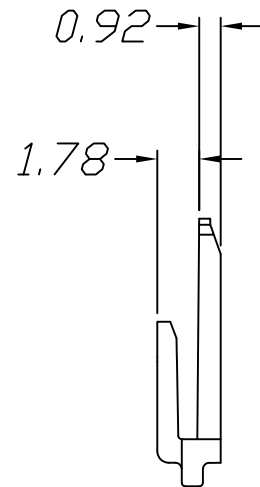
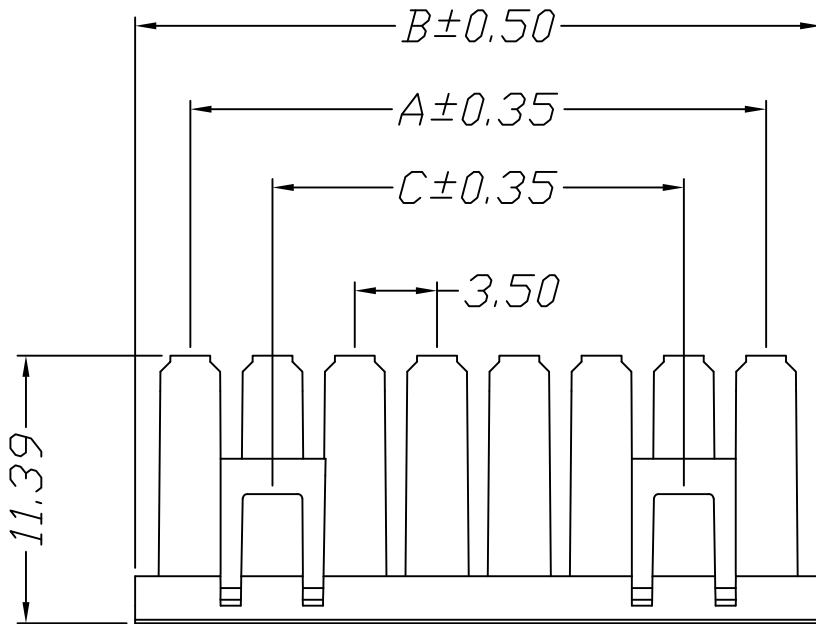
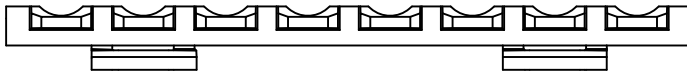

Poles	Dimensions		
	A	B	C
2P	3.50	8.20	3.50
3P	7.00	11.70	3.50
4P	10.50	15.20	3.50
5P	14.00	18.70	3.50
6P	17.50	22.20	17.50
7P	21.00	25.70	17.50
8P	24.50	29.20	17.50

Material	Color
PA66 UL94V-0	BLACK

	GENERAL TOLERANCES		SCALE: 1:1	NAME	DATE	深圳市思拓展电子有限公司 SHENZHEN SINOTOP ELECTRONICS CO., LTD 公司网址: www.szstuo.cn 公司电话: 0755-23765350 邮 箱: 2850175982@qq.com 公司传真: 0755-23765341	PART. NO: STP43501B00-NPX-66
	LINEAR	ANGLES	APPROVED				DWG. NO:
UNIT: MM	0.0±0.35	X° REF±6°	DESIGNER			TITLE: 3.50mm PITCH RETAINER	REV: A0 SHEET: 1/1
SIZE: A4	0.000±0.15	X° X'±2°	DRAWN	肖坤权	2017.06.16		