

仅供参考

REV.	REVISION RECORD	DATE
A0	新图面发行	2017.06.16

Specifications:
 Voltage Rating : 250V AC/DC
 Current Rating : 8A AC,DC
 Withstand Voltage : 1500V AC/minute
 Contact Resistance : 40mΩ(MAX.)
 Insulation Resistance : 1000MΩ(MIN.)
 Temperature Range : -55°C~+105°C

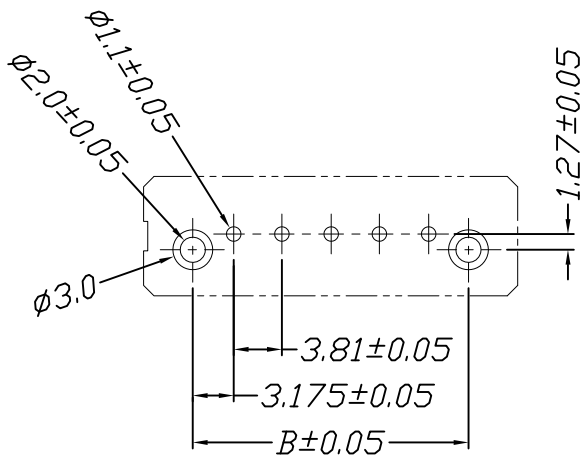
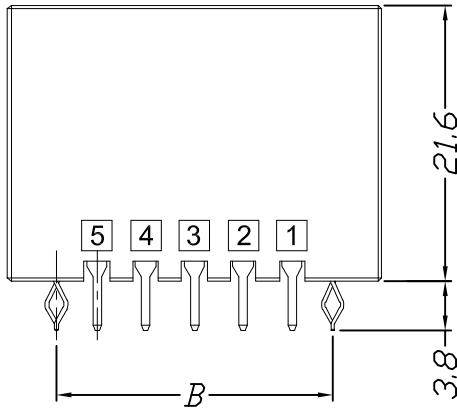
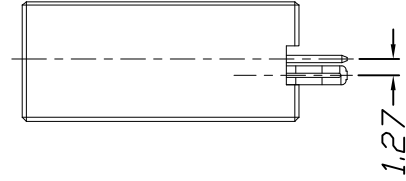
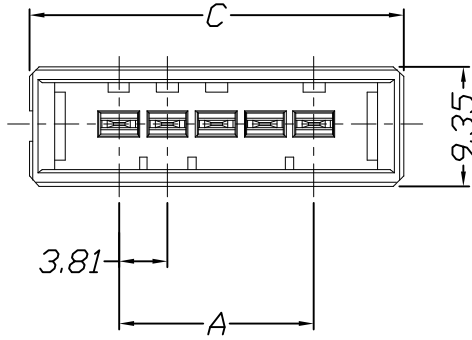
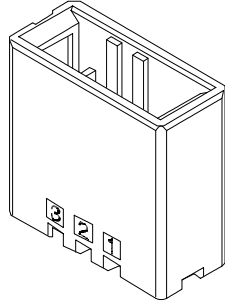

P.C.B. LAYOUT

Poles	Dimensions		
	A	B	C
3P	7.62	13.97	21.62
4P	11.43	17.78	25.43
5P	15.24	21.59	29.24
6P	19.05	25.40	33.05
8P	26.67	33.02	40.67
10P	34.29	40.64	48.29

Material	Color	PIN Material
PBT or Nylon	Black	Brass/Tin-plated

	GENERAL TOLERANCES		SCALE: 1:1	NAME	DATE
	LINEAR	ANGLES			
	0.0 ± 0.35	X° REF ± 6°	APPROVED		
UNIT: MM	0.00 ± 0.25	X° ± 3°	DESIGNER		
SIZE: A4	0.000 ± 0.15	X° X' ± 2°	DRAWN	肖坤权	2017.06.16

深圳市思拓展电子有限公司
 SHENZHEN SINOTOP ELECTRONICS CO., LTD
 公司网址: www.szstuo.cn 公司电话: 0755-23765350
 邮箱: 2850175982@qq.com 公司传真: 0755-23765341

TITLE:
3.81mm Pitch 180° Single Wafer DIP Type

PART NO:	STP43811W00-NPA-A1-XX	
DWG NO:		
REV:	A0	SHEET: 1/1

A B C D E F G H

仅供参考

REV.	REVISION RECORD	DATE
A0	新图面发行	2017.06.16

Specifications:

Voltage Rating : 250V AC/DC
 Current Rating : 8A AC,DC
 Withstand Voltage : 1500V AC/minute
 Contact Resistance : 15mΩ(MAX.)
 Insulation Resistance : 1000V DC/1000MΩ(MIN.)
 Temperature Range : -55°C~+105°C

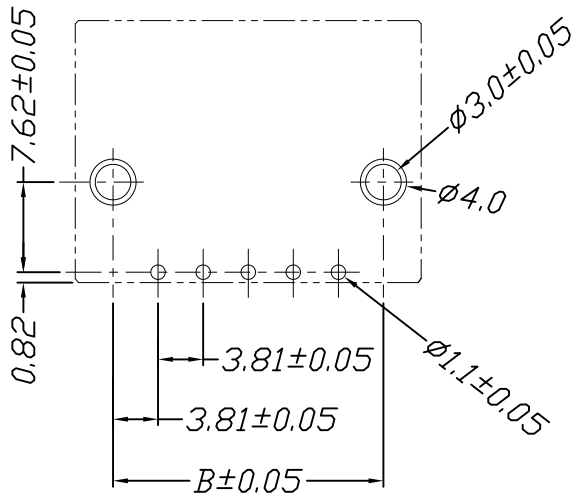
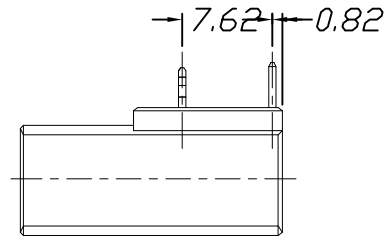
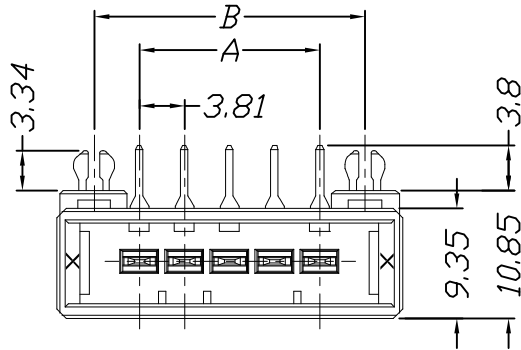
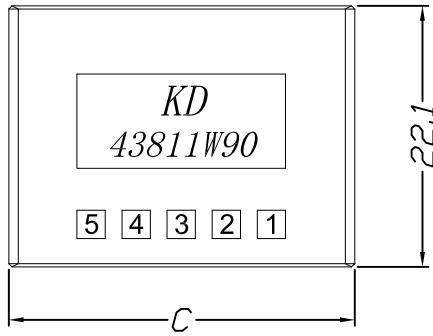

P.C.B. LAYOUT

Part No.	Dimensions		
	A	B	C
3P	7.62	15.24	21.62
4P	11.43	19.05	25.43
5P	15.24	22.86	29.24
6P	19.05	26.67	33.05
8P	26.67	34.29	40.67
10P	34.29	41.91	48.29

Material	Color	PIN Material
NYLON&PBT,UL94V-0	Black	Brass

	GENERAL TOLERANCES		SCALE: 1:1	NAME	DATE	深圳市思拓展电子有限公司 SHENZHEN SINOTOP ELECTRONICS CO., LTD 公司地址: WWW.SZSITUA.COM 公司电话: 0755-23765350 邮箱: 2850175982@qq.com 公司传真: 0755-23765341	PART. NO:
	LINEAR	ANGLES	APPROVED				STP43811W90-NPA-A1-XX
	0.0±0.35	X° REF±6°	DESIGNER				DWG. NO:
	UNIT: MM	0.00±0.25	X° ±3°	DRAWN	肖坤权		2017.06.16
SIZE: A4	0.000±0.15	X° X'±2°				TITLE:	SHEET: 1/1
						3.81mm Pitch 90° Dual Wafer DIP Type	

A B C D E F G H

仅供参考

REV.	REVISION RECORD	DATE
A0	新图面发行	2017.06.16

Specifications:
 Voltage Rating : 250V AC/DC
 Current Rating : 8A AC,DC
 Withstand Voltage : 1500V AC/minute
 Contact Resistance : 40mΩ(MAX.)
 Insulation Resistance : 1000MΩ(MIN.)
 Temperature Range : -55°C~+105°C

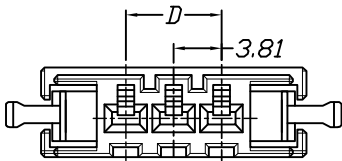
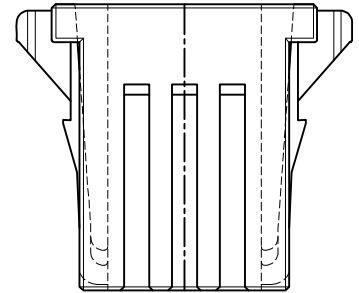
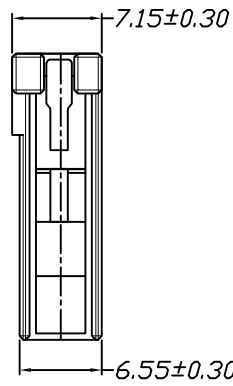
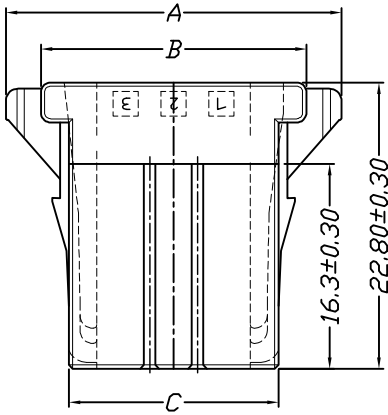
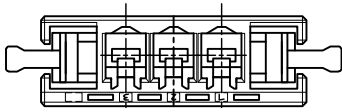
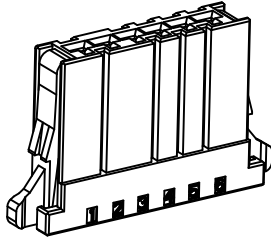

Poles	Dimensions			
	A	B	C	D
10P	53.43	47.83	43.37	34.29
8P	45.81	40.12	25.97	26.67
6P	38.19	32.59	28.13	19.05
5P	34.38	28.78	24.32	15.24
4P	30.57	24.97	20.51	11.43
3P	26.76	21.16	16.7	7.62

Material	Color
PBT UL94V-0	BLACK

	GENERAL TOLERANCES		SCALE: 1:1	NAME	DATE	深圳市思拓展电子有限公司 SHENZHEN SINOTOP ELECTRONICS CO., LTD 公司地址: www.szstuo.cn 公司电话: 0755-23765350 邮 箱: 2850175982@qq.com 公司传真: 0755-23765341	PART. NO: STP43811H00-NPA-PT
	LINEAR	ANGLES					
UNIT: MM	0.00±0.25	X° REF±6°	DESIGNER			TITLE:	DWG. NO:
SIZE: A4	0.000±0.15	X° X'±2°	DRAWN	肖坤权	2017.06.16	3.81mm PITCH Housing	REV: A0 SHEET: 1/1

仅供参考

REV.	REVISION RECORD	DATE
A0	新图面发行	2017.06.16

Specifications:
 Voltage Rating : 250V AC/DC
 Current Rating : 8A AC,DC
 Withstand Voltage : 1500V AC/minute
 Contact Resistance : 40mΩ(MAX.)
 Insulation Resistance : 1000MΩ(MIN.)
 Temperature Range : -55°C~+105°C

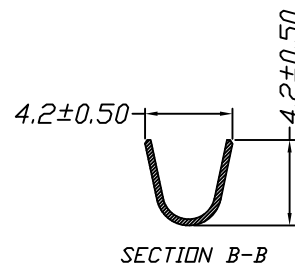
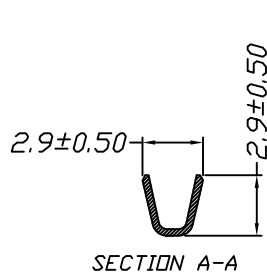
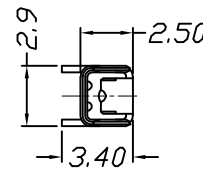
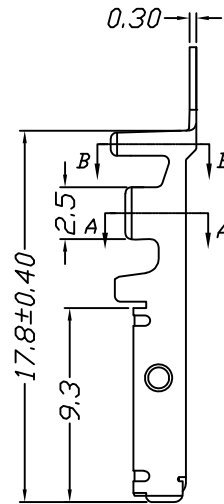
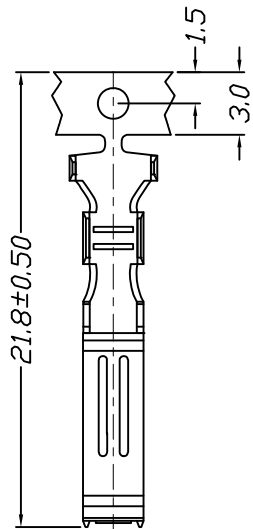

Wire Range	Insulation O.D.	Material	Finish	Qty/Reel
AWG #16~#20	1.25mm Max	Phosphor bronze	Au or Sn	

	GENERAL TOLERANCES		SCALE: 1:1	NAME	DATE	深圳市思拓展电子有限公司 SHENZHEN SINOTOP ELECTRONICS CO., LTD 公司网址: www.szstuo.cn 公司电话: 0755-23765350 邮箱: 2850175982@qq.com 公司传真: 0755-23765341	PART. NO: STP43811T0P-XX
	LINEAR	ANGLES	APPROVED				DWG. NO:
UNIT: MM	0.0±0.35	X° REF±6°	DESIGNER			TITLE:	REV: A0 SHEET: 1/1
SIZE: A4	0.000±0.15	X° X'±2°	DRAWN	肖坤权	2017.06.16	3.81mm PITCH Crimp Terminal	

仅供参考

REV.	REVISION RECORD	DATE
A0	新图面发行	2017.06.16

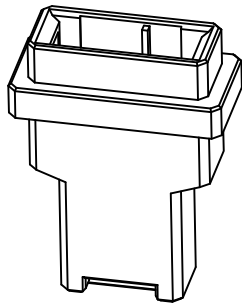

Specifications:
 Voltage Rating : 250V AC/DC
 Current Rating : 8A AC,DC
 Withstand Voltage : 1500V AC/minute
 Contact Resistance : 40mΩ(MAX.)
 Insulation Resistance : 1000MΩ(MIN.)
 Temperature Range : -55°C~+105°C

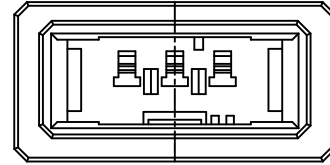
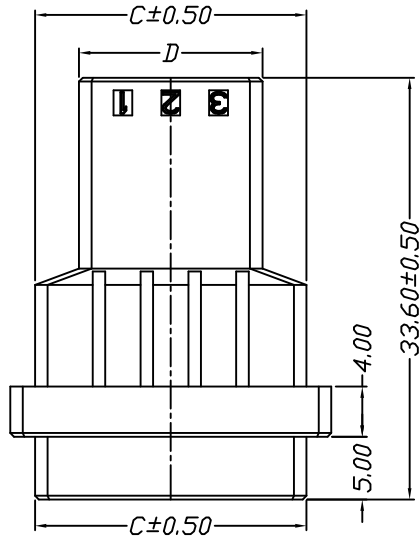

3P右防呆专用规格

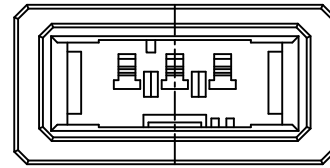

3P左防呆专用规格

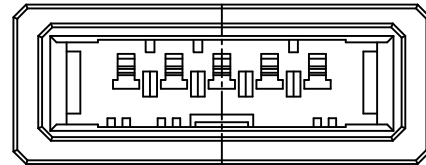

其它规格

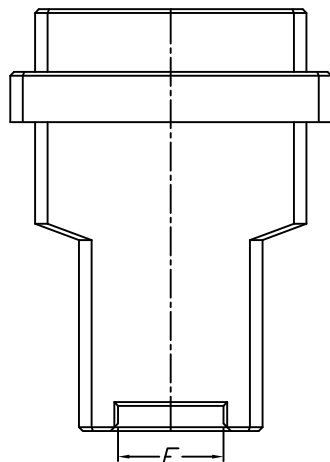
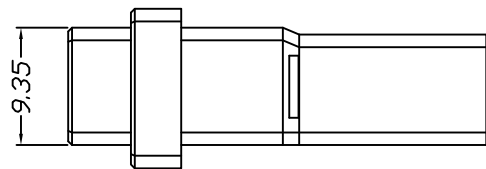
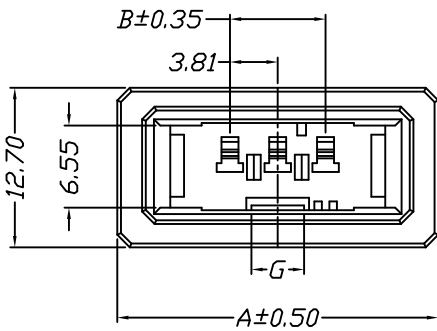

Poles	Dimensions					
	A	B	C	D	F	G
10P	52.24	34.29	48.29	41.29	18.4	4.0
8P	44.62	26.67	40.67	33.67	18.4	4.0
5P	33.19	15.24	29.24	22.24	18.4	4.0
3P	25.57	7.62	21.62	14.62	8.4	2.0

Material	Color
PBT UL94V-0	BLACK

	GENERAL TOLERANCES		SCALE: 1:1	NAME	DATE	深圳市思拓展电子有限公司 SHENZHEN SINOTOP ELECTRONICS CO., LTD 公司地址: WWW.SZSITUAO.CN 公司电话: 0755-23765350 邮箱: 2850175982@qq.com 公司传真: 0755-23765341	PART. NO:
	LINEAR	ANGLES	APPROVED				STP43811H00-NPA-2-PT
	0.0±0.35	X° REF±6°	DESIGNER				DWG. NO:
	UNIT: MM	0.00±0.25	X° ±3°	DRAWN	肖坤权		2017.06.16
SIZE: A4	0.000±0.15	X° X'±2°	TITLE: 3.81mm PITCH Housing				SHEET: 1/1

A B C D E F G H

仅供参考

REV.	REVISION RECORD	DATE
A0	新图面发行	2017.06.16

Specifications:
 Voltage Rating : 250V AC/DC
 Current Rating : 8A AC,DC
 Withstand Voltage : 1500V AC/minute
 Contact Resistance : 40mΩ(MAX.)
 Insulation Resistance : 1000MΩ(MIN.)
 Temperature Range : -55°C~+105°C

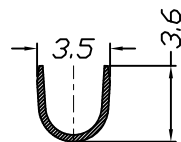
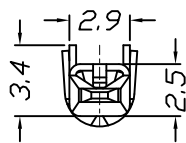
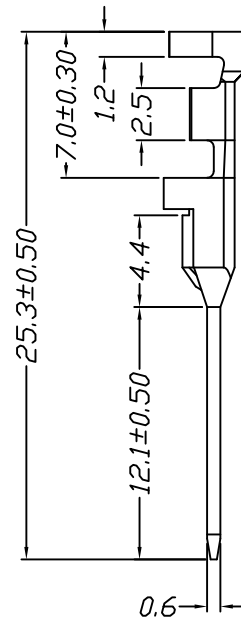
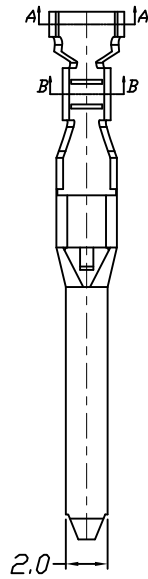

SECTION A-A

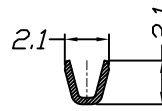

SECTION B-B

Wire Range	Insulation O.D.	Material	Finish	Qty/Reel
AWG #20~#24	1.20mm Max	Phosphor bronze	Au or Sn	

	GENERAL TOLERANCES		SCALE: 1:1	NAME	DATE	深圳市思拓展电子有限公司 SHENZHEN SINOTOP ELECTRONICS CO., LTD 公司网址: www.szstuo.cn 公司电话: 0755-23765350 邮箱: 2850175982@qq.com 公司传真: 0755-23765341	PART. NO: STP33811T0P-XX-T
	LINEAR	ANGLES	APPROVED				DWG. NO:
UNIT: MM	0.0±0.35	X° REF±6°	DESIGNER			TITLE: 3.81mm PITCH Crimp Terminal	REV: A0 SHEET: 1/1
SIZE: A4	0.00±0.15	X° X'±2°	DRAWN	肖坤权	2017.06.16		